

## TAILGRIP OPEN WEDGE SOCKETS WITH PIN

## QUENCHED AND TEMPERED CAST STEEL

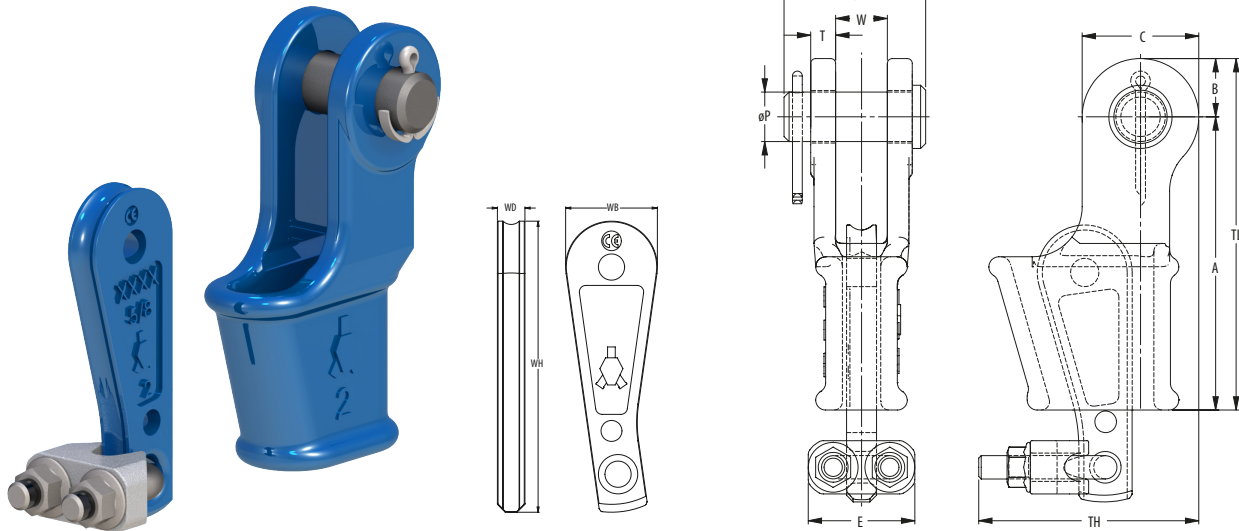

Model nr.	MBL (Mtons)	for wire ø		Dimensions (mm)													Weight (kg)
		(mm)	(inch)	A	B	C	E	øP	T	TH	TL	TB	W	WH	WB	WD	
OWS-TG 0.5 P	12	9-10	3/8	145	23	46	40	21	11	76	168	63	21	130	36	12	1,9
OWS-TG 1 P	20	11-13	1/2	157	29	57	55	25	12	100	185	67	25	170	48	14	2,4
OWS-TG 2 P	25	14-16	5/8	190	35	70	64	30	15	125	225	85	31	195	57	18	5
OWS-TG 3 P	40	18-19	3/4	210	40	80	68	35	16	142	250	95	38	222	70	21	8
OWS-TG 4 P	55	20-22	7/8	252	48	95	74	41	18	164	300	110	44	251	77	24	11
OWS-TG 5 P	75	23-26	1	298	55	110	84	51	22	189	353	128	51	274	83	28	16
OWS-TG 6 P	90	27-29	1 1/8	322	65	130	95	57	25	217	387	142	57	292	91	30	23
OWS-TG 7 P	110	30-32	1 1/4	350	73	146	105	63	28	238	423	155	63	349	108	33	34
OWS-TG 8 P	125	34-36	1 3/8	400	74	148	117	64	28	263	474	160	70	394	116	35	38

MBL = Minimum Breaking Load

- The standard finish of our sockets is blue. Hot dipped galvanized is also available.
- All sockets are provided with an EN 10204-2.1 declaration of conformity, EN 10204-3.1 material certificate and can be provided with a 2006/42/EC declaration where applicable.
- Dimensional tolerances depend on the manufacturing techniques applied and are different between machined components (pins) and cast components (socket bodies and wedges).
- Also surface finish e.g. hot dip galvanizing or even paint may add to the overall thickness and fork distance.
- Please contact Ropeblock for further guidance and a detailed dimensional tolerance sheet.

