

Can also be delivered with:

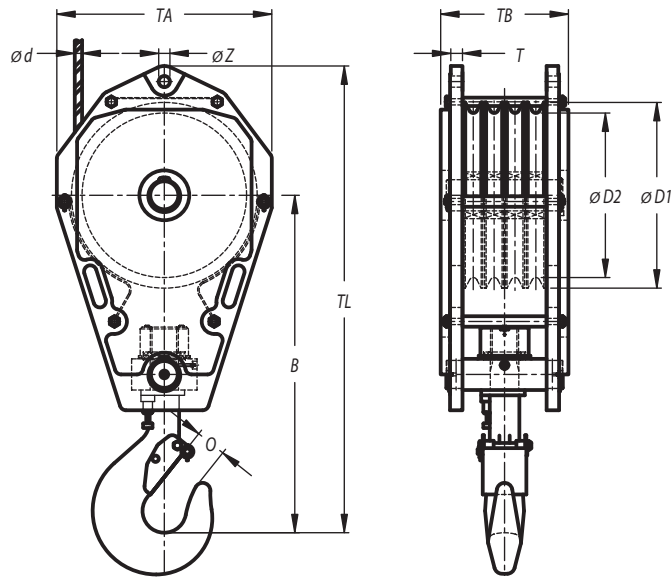

Stock No.	Model No.	WLL (t)	Wire (mm)	Dimensions (mm)									Weight (kg)
				ØD1	ØD2	B	O	TA	TB	TL	T	ØZ	
23.320.035.41	FRB 285.4.35	35	15-16	320	285	720	76	400	312	1030	28	32	275
23.410.050.41-1	FRB 355.4.50	50	17-19	410	355	915	84	500	363	1255	35	37	500
23.410.050.41-2	FRB 355.4.50	50	20-22	410	355	915	84	500	363	1265	40	43	500
23.460.063.41	FRB 400.4.63	63	20-22	465	400	985	97	570	350	1365	40	43	550
23.515.063.41	FRB 450.4.63	63	20-22	515	450	1025	97	600	400	1435	40	43	750
23.515.080.41	FRB 450.4.80	80	24-26	515	450	1190	110	600	517	1580	40	52	1000
23.595.100.41	FRB 520.4.100	100	27-28	596	528	1290	132	710	462	1765	40	59	1250

Minimum Ultimate Strength = 4 x WLL.

- Standard fitted with cylindrical roller bearing, reeving guide and becket.
- Standard painted in yellow with black stripes.
- Standard sheaves of reeve blocks can be adjusted to other wire rope diameters.
- Third party testing with certification available upon request.
- Standard fitted with hook according DIN 15401