

Can also be delivered with:

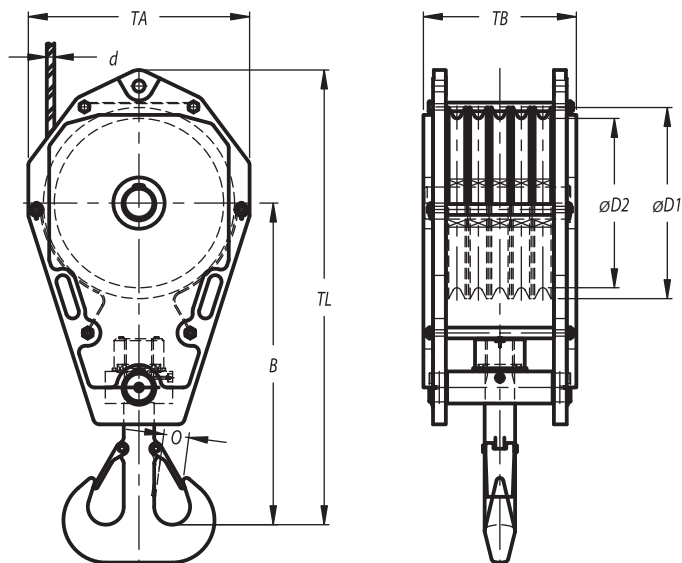

Stock No.	Model No.	WLL (t)	Wire d (mm)	Dimensions (mm)									Weight (kg)
				ØD1	ØD2	B	O	TA	TB	TL	T	ØZ	
23.280.025.51	FRB 250.5.25	25	11-12	280	250	780	47	360	310	980	22	27	290
23.320.032.51	FRB 285.5.32	32	13-14	320	285	850	57	400	310	1075	28	32	350
23.365.040.51	FRB 320.5.40	40	15-16	365	320	920	60	450	440	1150	28	32	475
23.410.050.51	FRB 355.5.50	50	17-18	410	355	950	60	500	440	1200	35	37	600
23.460.063.51	FRB 400.5.63	63	19-20	460	400	1025	63	550	450	1325	40	43	700
23.515.080.51	FRB 450.5.80	80	21-22	515	450	1250	73	600	450	1575	40	43	850
23.595.100.51	FRB 520.5.100	100	24-26	595	520	1350	87	680	450	1700	45	52	1050
23.650.125.51	FRB 570.5.125	125	28-29	650	570	1560	108	750	575	1950	50	59	1400
23.720.160.51	FRB 630.5.160	160	30-32	720	630	1800	112	850	575	2250	60	65	1800

Minimum Ultimate Strength = 4 x WLL.

- Standard fitted with cylindrical roller bearing, reeving guide and becket.
- Standard painted in yellow with black stripes.
- Standard sheaves of reeve blocks can be adjusted to other wire rope diameters.
- Third party testing with certification available upon request.
- Standard fitted with hook according to DIN 15401