

Can also be delivered with:

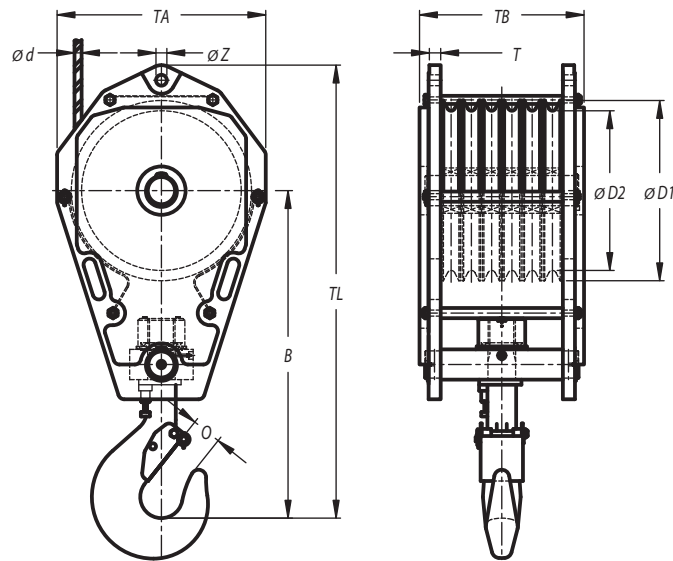

Stock No.	Model No.	WLL (t)	Wire (mm)	Dimensions (mm)									Weight (kg)
				ØD1	ØD2	B	O	TA	TB	TL	T	ØZ	
23.460.072.61	FRB 400.6.72	72	17-19	460	400	1100	110	570	397	1450	30	37	650
23.515.080.61	FRB 450.6.80	80	20-22	515	450	1190	110	600	612	1580	40	43	1200
23.595.125.61	FRB 520.6.125	125	24-26	596	528	1325	137	710	652	1765	45	52	1750
23.595.160.61	FRB 520.6.160	160	24-26	596	528	1400	167	710	842	1900	45	52	2970
23.595.200.61	FRB 520.6.200	200	27-28	596	528	1600	188	710	882	2110	50	59	3680

Minimum Ultimate Strength = 4 x WLL.

- Standard fitted with cylindrical roller bearing, reeving guide and becket.
- Standard painted in yellow with black stripes.
- Standard sheaves of reeve blocks can be adjusted to other wire rope diameters.
- Third party testing with certification available upon request.
- Standard fitted with hook according DIN 15401